

Operating Instructions

Electronic Rice Cooker/Warmer

電子保溫飯煲

전자 밥솥/보온기

Cuiseur de riz/réchaud électronique

SR-TE10N/TE15N/TE18N



Panasonic®

Before operating this unit, please read these instructions completely.

在使用本機前，請詳細閱讀此使用說明書。

사용하시기 전에 이 설명서를 잘 읽으실 것.

Il est recommandé de lire attentivement ce manuel avant d'utiliser l'appareil.

IMPORTANT SAFEGUARDS

When using electrical appliances, basic safety precautions should always be followed including the following:

1. Read all instructions.
2. Do not touch hot surfaces. Use handles or knobs.
3. To protect against electrical hazards, do not immerse cord, plugs, and Rice Cooker, except lid and pan, in water or other liquid.
4. Close supervision is necessary when any appliance is used by or near children.
5. Unplug from outlet when not in use and before cleaning. Allow to cool before putting on or taking off parts.
6. Do not operate any appliance with a damaged cord or plug or after the appliance malfunctions, or has been damaged in any manner. Return appliance to the nearest authorized service facility for examination, repair, or adjustment.
7. The use of accessory attachments not recommended by the appliance manufacturer may cause hazards.
8. Do not use outdoors.
9. Do not let cord hang over edge of table or counter, or touch hot surfaces.
10. Do not place on or near a hot gas or electric burner, or in a heated oven.
11. Extreme caution must be used when moving an appliance containing hot oil or other hot liquids.
12. Always attach plug to appliance first, then plug cord into the wall outlet. To disconnect, turn any control to "off", then remove plug from wall outlet.
13. Do not use appliance for other than intended use.

14. SAVE THESE INSTRUCTIONS

This product is intended for household use.

NOTE

- A. A short power-supply cord (or cord set) is to be provided to reduce the hazards resulting from becoming entangled in or tripping over a longer cord.
- B. Longer cord set or extension cords are available and may be used if care is exercised in their use.
- C. If a long cord set or extension cord is used,
 - (1) the marked electrical rating of the cord set or extension cord should be at least as great as the electrical rating of the appliance.
 - (2) if the appliance is of the grounded type, the extension cord should be a grounding-type three-wire cord, and
 - (3) the longer cord should be arranged so that it will not drape over the countertop or tabletop where it can be pulled on by children or tripped over accidentally.

This appliance has a polarized plug: (one blade is wider than the other). As a safety feature, this plug will fit in a polarized outlet only one way. If the plug does not fit fully in the outlet, reverse the plug. If it still does not fit, contact a qualified electrician. Do not attempt to defeat this safety feature.

Contents

Cautions	3
Parts Identification	4
How to Cook	5-6
To Keep Cooked Rice Warm and Tasty	6
How to Steam Food (Using the Steaming basket)	7
How to Clean	8
Troubleshooting	9
Specifications	9

注意事項	10
零件名稱	11
使用方法	12-13
使已煮熟米飯保溫及可口	13
蒸食方法 (使用選購蒸架時)	14
清洗方法	15
故障檢修	16
規格	16

주의사항	17
각 부품의 이름	18
조리법	19-20
조리된 밥을 맛있고 따뜻하게 유지하기	20
찜 용기를 사용해서 하는 찜 요리법	21
청소법	22
문제해결	23
사양	23

Table des matières

Attention	24
Nomenclature	25
Mode d'emploi	26-27
Pour maintenir le riz cuit au chaud et lui conserver toute sa saveur	27
Cuisson à la vapeur (Avec grille à vapeur en option)	28
Nettoyage	29
Guide de dépannage	30
Spécifications	30

Cautions

ENGLISH

Be sure to observe the following to prevent malfunction that may cause an accident:

- DO NOT use this rice cooker for any purpose other than cooking rice and steaming food.
- Measure the quantity of rice and water according to the Operating Instructions.
- Clean the rice cooker, particularly the dew collector, after using.
- Keep holes that drain into the dew collector clean and free of debris.
- Plug into a properly wired wall outlet. Before you plug it in, make sure the voltage of the unit is the same as your local supply.
- DO NOT immerse the unit in water.

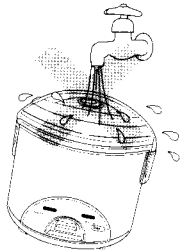

- The paper located between the pan and the heating plate must be removed before using.
- After plugging in, press the switch on immediately. Cooking with the switch in Keep Warm position will cause low-heat cooking and rice will not be cooked properly.
- The unit becomes hot when in use. DO NOT touch the lid with your hand, and do not place your face or hand directly over the steam coming from the cooker.
- Always keep the outside bottom of the pan and the heating plate clean and dry. Any foreign matter between them will cause the unit to malfunction.

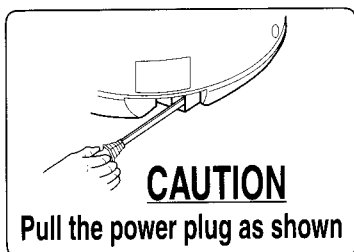

- Set the unit on a stable surface. DO NOT expose to water, high humidity, or heat sources. DO NOT use the pan directly on an open flame.

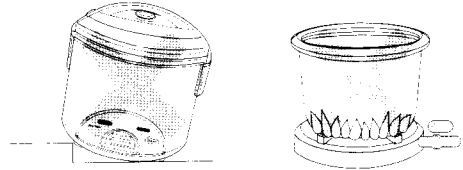

- Be sure to keep the unit out of the reach of children, especially when cooking rice.
- DO NOT tilt the rice cooker on its edge or place it upside down with its power supply plug connected, as this may cause damage. When tilting or placing the rice cooker upside down, make sure to disconnect the power supply plug.
- The pan must not be filled above the "MAXIMUM LEVEL".
- The lid must be closed tightly in the latched position at all times during cooking, i.e. the unit must not be operated with the lid opened.
- DO NOT cover the lid with a cloth as it may deform or change color.

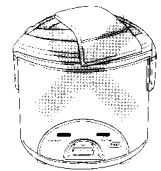

- DO NOT damage the power cord and do not attempt to repair it if it is damaged. Avoid damage to the power cord. Never attempt to customize the cord. Keep the cord away from high temperatures. Avoid unnecessary bending, twisting and pulling on the cord. Never place heavy objects on the cord or attempt to tie it up. Using a damaged power cord can lead to electrical shock, shorting or fire.
 - Consult your nearest sales dealer for repair of the electrical cord or power plug.
- Ensure that the plug fits all the way into the outlet. Uncompleted plug-in may cause electrical hazards.
 - Please use only attached cord set.

Parts Identification

Steam cap

- Remove and clean after every use. See "How to Clean". (page. 8)

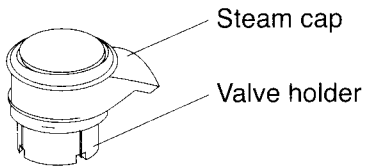

Dew collector

- Hold the sides and remove/install in the direction of the arrows.
- Remove and clean the dew collector after every use.

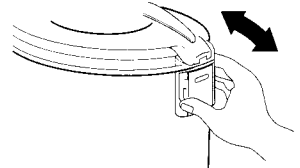

Scoop holder

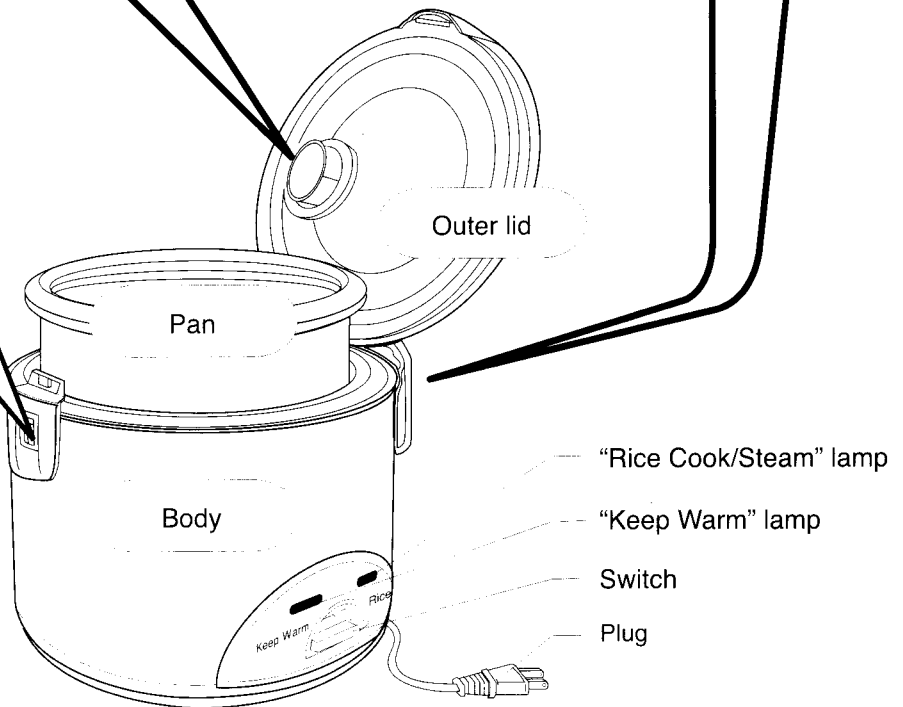
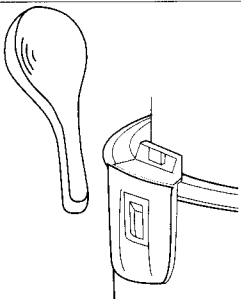

Accessories

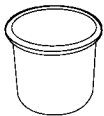

Measuring cup
(Approx. 180ml)



Rice scoop



Steaming basket

How to Cook

ENGLISH

1 Measure rice with the measuring cup provided. Rinse rice in a separate bowl until the water becomes relatively clear.

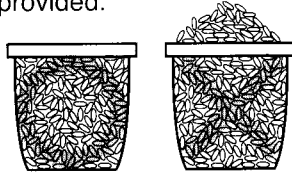

- Do not rinse rice in the rice cooker pan as non-stick coating may be damaged.

2 Place rinsed rice in the pan. Add water, e.g. for 6 cups of rice, add water to LEVEL INDICATOR 6.

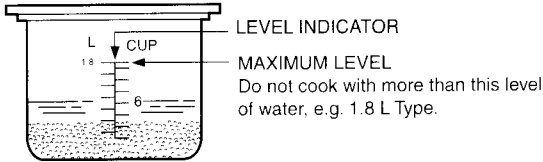

- Adjust the quantity of water to your personal taste.
- Soak rice in water at least for 30 minutes.

3 Set the steam cap onto the outer lid. Place the pan in the body. Make sure that the pan is directly in contact with the heating plate by turning it slightly from right to left until it seats properly.

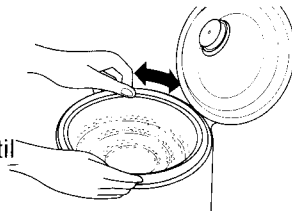

- Wipe the surface of the pan before using. If it is wet, it may cause noise while cooking. It may also damage the unit, if any foreign matter is on it.

4 Close the outer lid. The lid is locked properly when it clicks.



- If outer lid is not securely closed, cooking will be affected.
- Do not open the outer lid when in use.

5 Plug in. Immediately press the switch. The "Rice Cook/Steam" lamp tells you when cooking has started.

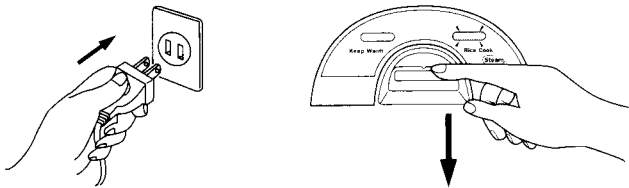

- Do not plug in unit until you get ready to cook. Otherwise, rice may be ruined.
- If the pan is not in the unit, cooking will not begin.

6 When rice is done, the switch will move up to the "Keep Warm" setting. The "Keep Warm" lamp lights up to indicate that the "Keep Warm" function is working.

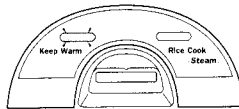

- The "Keep Warm" function continues until the unit is unplugged.

7 After the switch moves up, leave the outer lid closed for at least 15 minutes to fully steam the rice.

How to Cook

8

Scoop and mix the rice well
20-30 minutes after cooking is done.

Scoop holder

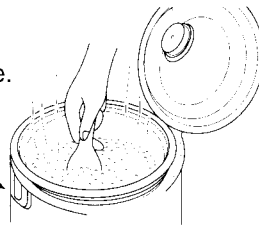

9

Unplug the unit if you do not want to keep
the rice warm or when the unit is not in use.

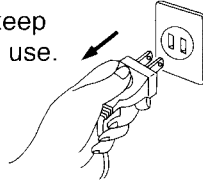

10

Remove and clean the dew
collector after every use.

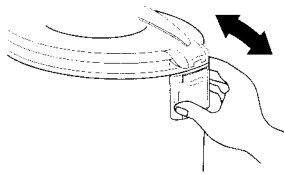

To Keep Cooked Rice Warm and Tasty

- Using the Keep Warm function for more than 12 hours may cause discoloration or an odor in the rice.
- If quantity of rice to be kept warm is less than

SR-TE18N	6 bowlfuls (6 cups)
SR-TE15N	4 bowlfuls (4 cups)
SR-TE10N	2 bowlfuls (2 cups)

the rice will gradually dry out and lose its flavour.

- Foreign matters left in the pan during Keep Warm may affect the smell and taste of the rice.

How to Steam Food (Using the Steaming basket)

1

Put 2 cups of water with the measuring cup provided, into the pan.

If cooking rice at the same time, DO NOT cook beyond following capacity.

	Rice (cups)
1.8L (10 cups)	5
1.5L (8 cups)	4
1.0L (5 cups)	2

2

Place steaming basket on the pan.

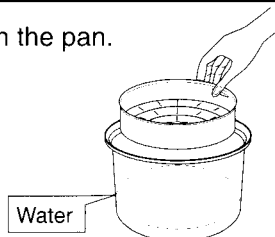

3

Set the pan into the body.
Add food.(Place in dish if Required)

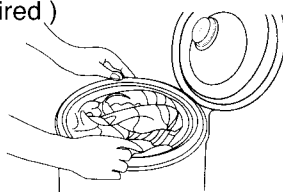

- Wipe the surface of the pan before using. If it is wet, it may cause noise while cooking. It may also damage the unit, if any foreign matter is on it.

4

Set the steam cap onto the outer lid. Close the outer lid. The lid is locked properly when it clicks.

Plug in. Immediately press the switch. The "Rice Cook/Steam" lamp tells you when cooking has started.

- If outer lid is not securely closed, cooking will be affected.
- DO NOT plug in until you are ready to cook.
- If the pan is not in the unit, cooking will not begin.

5

Time the cooking manually.
*Unit will automatically switch to Keep Warm when water is completely evaporated.

6

Turn off cooker by unplugging.

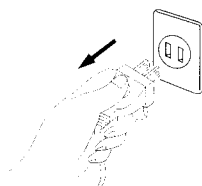

- The "Keep Warm" function continues until the unit is unplugged.

7

Remove foods, then the steaming basket, and finally pour out any remaining water.

How to Clean

- Be sure to unplug and carry out these operations when the unit has cooled down.
- DO NOT use objects such as benzine, thinner, cleansing powder or metal scrubbers.

Body / Outer lid / Upper rim

Wipe with a damp cloth.

- DO NOT use a dishwashing detergent.

Pan

Wash with a dishwashing detergent and sponge and wipe off.

Dew collector

Remove and clean with damp cloth after every use.

Pan sensor

If an object has become stuck to the sensor, lightly polish it off by using fine sandpaper (of about #600 grit)/ steel wool. Then, wipe with a damp cloth.

Accessories

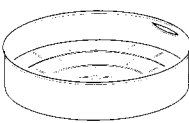

Steaming basket

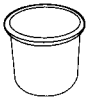

Measuring cup



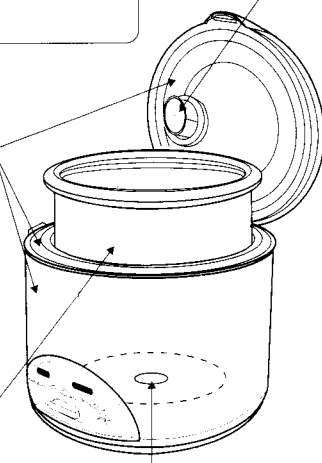

Rice scoop

Wash with a dishwashing detergent and sponge.

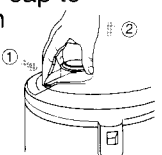

Steam cap

■ How to remove and clean.

1. Pull off the steam cap to remove as shown in the figure.
 
2. Remove the valve holder by turning it from right to left. Wash and wipe with a damp cloth.
 

DO NOT remove rubber.

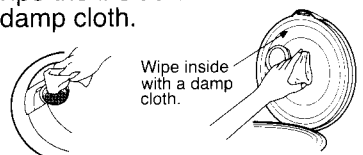
3. Wipe the inside of the hole with a damp cloth.
 

Please do not remove steam dome when using rice cooker

■ How to fit steam cap.

1. Insert the valve holder into the steam cap by setting the tab of the holder (A) into the slot of the cap (B) and turn it from left to right until it seats properly.

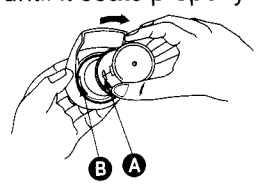

■ How to fit steam dome.

(In case it's accidentally taken off)

Place steam dome into its holder by inserting steam dome tabs (C) into slot (D). Align mark on dome (1) and mark on steam cap (2). Then, press steam dome into steam cap until it seats properly (You'll hear the sound "click")

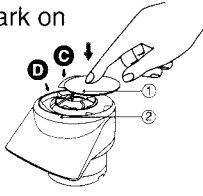

Note : The steam dome will only fit one way. Do not force it in as it may be damaged.

2. Put the steam cap into the hole of outer lid.

Troubleshooting

Problems Description	Cooking Problems					Keep Warm Problems			No power	Emits strange sounds
	Rice too hard	Rice not cooked to the center	Rice too soft	Viscous liquid overflows	Bottom is scorched	Rice has unusual smell	Rice changes color	Rice is too dry		
Rice to Water ratio not correct	●	●	●	●	●				Unplug the unit from the wall socket. Check circuit breaker. If circuit breaker is ok then take unit to the nearest authorized service center.	Popping sounds are caused when water trapped between the pan and the heater evaporates. This can cause damage to the pan and heater.
Rice not rinsed well enough					●	●				
Pan bottom dented or uneven	●	●			●					
Foreign matter between pan and heater	●	●	●		●	●				
Rice Cooked with oil	●	●				●				
Rice not fluffed (mixed) after cooking	●		●							
Keep Warm for longer than 12 hrs or amount of rice being kept warm is too small						●	●	●		
Utensils left in pan during Keep Warm						●				
Rice being kept warm was at room temperature or colder or cold rice added to warm rice						●				
Lid not securely closed						●				
Pan was not clean or odors from previous cooking remain in pan					●	●				
Power cord was unplugged or the switch was turned off during cooking		●				●				

Specifications

Model No.	SR-TE10N	SR-TE15N	SR-TE18N
Power supply		120 V	
Power consumed at Rice Cook	450 W	630 W	630 W
Power consumed at Keep Warm	61 W	67 W	67 W
Capacity	0.18-1.0 L	0.36-1.5 L	0.54-1.8 L
Dimension (H x W x D) (approx.)	9 ⁵ / ₈ " x 9 ³ / ₄ " x 9 ³ / ₄ " (245 x 248 x 247 mm)	9 ³ / ₄ " x 10 ⁷ / ₈ " x 10 ³ / ₄ " (248 x 276 x 274 mm)	10 ¹ / ₂ " x 10 ⁷ / ₈ " x 10 ³ / ₄ " (267 x 276 x 274 mm)
Weight (approx.)	2.5 kg (5 ¹ / ₂ lbs.)	2.8 kg (6 ¹ / ₄ lbs.)	3.1 kg (6 ³ / ₄ lbs.)

注意事項

請遵守下列事項，以免導致故障：

- 只適用於煮白米飯。
- 請按照說明書之指示量度米和水。
- 請經常保持飯煲清潔，不沾油污，並於使用後，把集水器內之積水倒去。
- 保持鍋蓋上的集水孔清潔及暢通。
- 將插頭插入適當配線的電煲專用插座。在接通電源之前，請確認一下電煲銘牌上的電壓是否和電源電壓相同。
- 不要將電煲浸入水中。

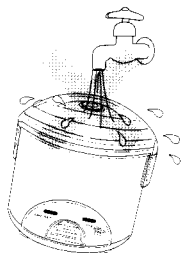

- 使用電飯鍋之前，先將隔開內鍋和電熱板之間的紙取出。
- 接通電源後，立刻按下開關。如果開關置於保溫位置，就成了低溫煮飯的原因，而不能正常煮飯。
- 電飯鍋在使用時有高溫，切勿用手接觸飯鍋，或將隻手及面孔觸到飯鍋中冒出之蒸汽。
- 內鍋底和電熱板的表面一定要保持清潔干燥。任何雜質都將引起電鍋發生故障。

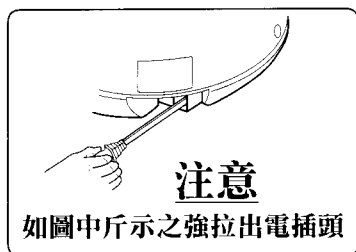

- 將電煲安放於隱定的平面。不要將其放於水中或高濕氣環境中或靠近其它熱源。不要將內鍋直接放於明火上。

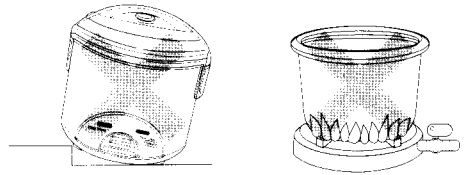

- 要保證將電煲放在小孩接觸不到的地方，特別是在煮飯的時候。
- 在插入電源插頭狀態下，請勿將電飯煲明顯地傾斜或倒置，否則會導致故障。此時，請務必先拔下電源插頭後進行之。
- 請勿讓內鍋裡的水超過“MAXIMUM LEVEL（最高水位）”。
- 在整個煮飯過程中，蓋子必須蓋牢在扣鎖位置。（也就是說，電煲在操作時不允許敞開蓋子。）
- 請不要用布蓋在煲蓋上。煲蓋可能會因此變形或變色。

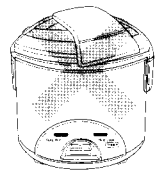

- 不要損壞電線，當電線損壞時，不要試行修理。避免損害及電線，不可變更電線，並避免將電線置於高溫之處，或作不必要之捲折，幻曲或強力拉扯電線，不可將電線重壓或試圖用電線來提起重物。使用損壞之電線，可能導致觸電，電流短路或引起火災。
- 電線或電插掣損壞，請向最鄰近貴府之代理店接洽修理。
- 確信電插掣已完全插入電飯鍋插座中。不完整的插電掣可能導致發生電流意外危險。
- 請僅使用附配之電線裝置。

零件名稱

蒸汽套

- 每次使用之後須將蒸汽套取出洗清潔須將請參閱“清潔與保養方法”(第15頁)。

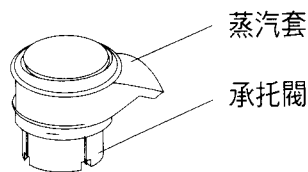

水滴收集器

- 抓住水滴收集器的兩邊拉下/按箭頭的方向將其裝上。
- 使用之後，水滴收集器取下並清洗乾淨。

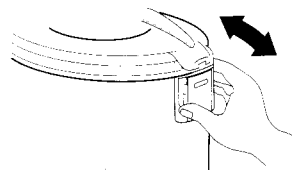

飯勺筒

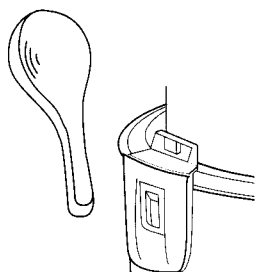

煮飯/蒸煮顯示燈

保溫指示燈

開關

電線

附件



量杯
(約180毫升)



飯勺子

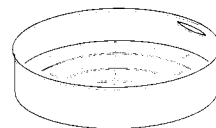

蒸籠

使用方法

1 用量杯量好米。請用清水在其它的盆裡洗米，直到水比較乾淨為止。

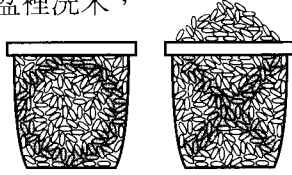

- 請不要在電鍋的內鍋裡洗米。因將損害及內鍋的不黏表層。

2 將洗好的米倒入內鍋，並適當加水。例如，要煮6杯米時，將水加至水位刻度“6”。

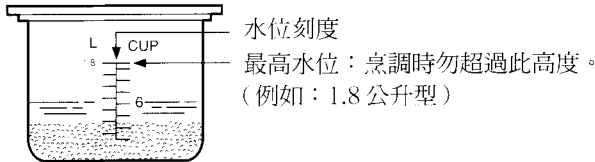

- 您可根據自己的喜好，適當地調整水量。
- 將白米泡在水中最少30分鐘。

3 將蒸格放進飯煲中，置入食物(如有需要可置於盤中)，一定要將內鍋直接放在加熱板上，向左、右側輕輕地轉動內鍋，便可使之固定得當。

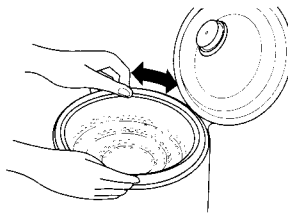

- 使用之前先將內鍋表面擦淨，如果潮濕，在煮飯時將發出噪音。如有雜物附在內鍋上，將會損及電飯煲部件。

4 蓋上外蓋，並確認咔嚓一響。



- 如果外蓋不完全蓋合，則將影響煮飯。
- 使用中請勿打開外蓋。

5 接通電源，立即按下開關掣。當飯煲開始煮飯時，會在煮飯/蒸煮燈上顯示出來。

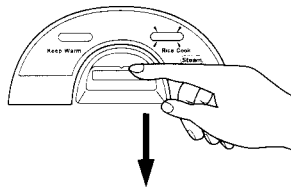
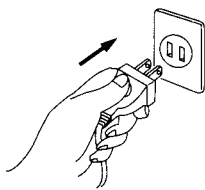

- 在煮飯的準備做好之前，請勿接通電源。否則米會受損失。
- 當內鍋不在電煲裡時，煮飯不會開始。

6 當飯煮好的時，開關會跳起。保溫“Keep Warm”指示燈點亮，表示進入保溫“Keep Warm”功能。

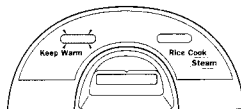

- 保溫功能將持續至拔出電源線為止。

7 在開關發出硬的一響後，至少在十五分鐘內不要打開煲蓋以便繼續蒸煮。

使用方法

8

飯煮熟後均勻地攪拌米飯
20-30 秒鐘。

飯勺筒

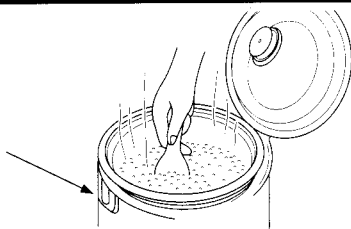

9

不想保溫或不使用電煲時，請拔下插頭。

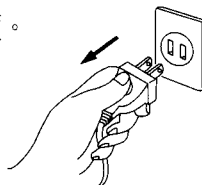

10

每次使用完畢後，應取下
水滴收集器進行清洗。

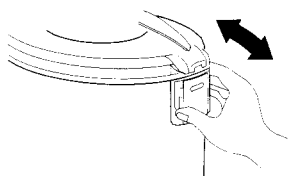

使已煮熟米飯保溫及可口

- 若保溫時間超過 12 小時，則米飯可能會變色或產生異味。
- 如果保溫的米飯量少於：

SR-TE18N	6 滿碗 (6 杯)
SR-TE15N	4 滿碗 (4 杯)
SR-TE10N	2 滿碗 (2 杯)

則米飯會逐漸變干並失去固有的香味。

- 保溫時內鍋中如有其它盛飯用具則會影響米飯的味道。

蒸食方法 (使用選購蒸架時)

1 用量杯量取 2 杯水倒入蒸格中。

- 如同時進行煮飯則煮飯不可超過限定之水位刻度。

容量

容量	量杯
1.8L (10 杯)	5
1.5L (8 杯)	4
1.0L (5 杯)	2

2 將蒸架放入內鍋。

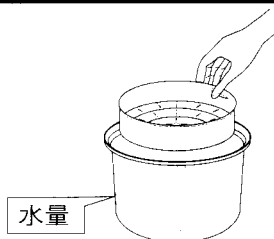

3 將蒸格放進飯煲中，置入食物（如有需要可置於盤中）

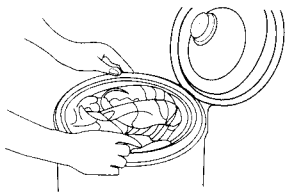

- 使用之前先將內鍋擦乾淨，如果潮濕，在煮飯時將發出噪音。且如有雜物附在內鍋上，將會損及部件。

4 蓋上外蓋，校好外蓋上的蒸汽套。當外蓋被蓋緊時，會發出噠的響聲。

將直流電線座入插座，立即按開關掣，煮飯 / 蒸煮燈會亮起，告訴您蒸食物工作正在進行。

- 如果外蓋沒有蓋緊，則會影響及煮飯之進行。

- 煮飯工作準備未停妥之時

- 不要插上插掣，否則飯會變得稀爛。

5 如果內鍋沒有置入電飯煲中，煮飯將無法進行。校定煮飯時間，

* 當飯煲中之水被蒸發，電飯煲電掣會自動轉到保溫掣上。

6 拔出插頭，停止熟調。

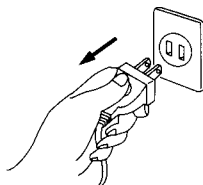

- 在拔出插掣之前，保溫系統仍照常操作。

7 取出食物及蒸格，並將鍋中剩餘之任何水份倒出。

清洗方法

- 當電飯煲熱度退盡冷卻之後，拔去插掣電源，進行清洗。
- 不要使用汽油，釋稀劑，清潔粉或毛刷等物質。

煲身/外蓋/上面邊緣

用濕布揩拭

- 不可使用洗碗碟清潔劑

內鍋

可用洗碗碟清潔劑沖洗，然後以海綿揩拭清潔。

蒸汽水收集器

每次使用後須取下清洗用濕布揩淨。

內鍋傳感器

如果有物品黏附著傳感器，請輕輕磨擦去，用幼砂紙（約為 # 600 號）或鋼絲輕擦拭，然後以濕布揩淨。

配件



蒸籠



量杯



飯杓

可用洗碗碟清潔劑與海綿揩拭。

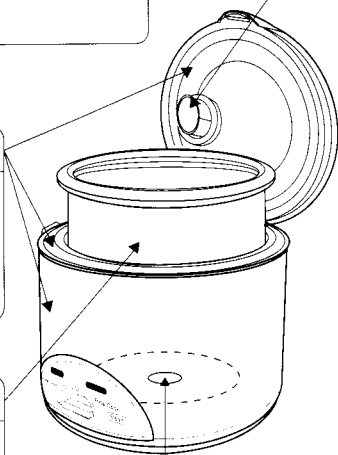

蒸汽套

■ 如何取下及清潔

1. 將蒸汽套拉出取下，一如圖中所示。

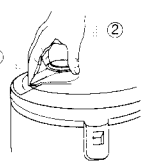

2. 自右向左旋轉取下蒸汽閥座。用濕布揩拭清潔。

橡皮圈不必取出



3. 用濕布將蒸汽套洞內部揩拭乾淨。當煮飯正進行時不可取下蒸汽套蓋。

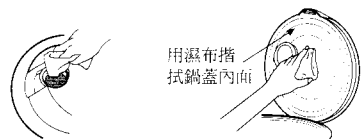

用濕布揩拭鍋蓋內沿

■ 如何裝置蒸汽套

1. 將汽閥座安裝進蒸汽套方法，先將汽閥座 塞子 (A) 裝入蒸汽套槽 (B)，自左至右旋至鏗合。

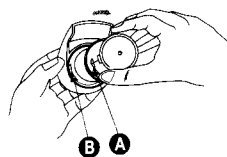

- 如何安裝蒸汽套蓋 (在無意中取出的情況下) 將蒸汽套蓋放進座中，讓蒸汽蓋 (C) 納入槽中 (D)。在裝置時注意應在蒸汽套蓋 (1) 作記號及在蒸汽套 (2) 作記號。然後將套蓋緊按至納入正確位置



(您將會聽到“噠”的響聲)。注意：蒸汽套蓋僅作單向旋轉，切勿用力敲擊，因將使套蓋損壞。

2. 將蒸汽套放進飯鍋外蓋的小洞中。

故障檢修

發生下列情況時	煮飯時的問題					保溫時的問題			電流中斷	使用中發出嘈音
	過硬	未煮熟 (底部沒熟)	過軟	米湯溢出	鍋已過於焦黑	發出怪味	變色	飯太乾		
檢查項目										
● 米量、水量不正確	●	●	●	●	●				● 插掣未插入牆壁之插座，檢查保險掣是否中斷，如保險掣正常，則須將電飯鍋送至最鄰近之修理店修理。	● 煮飯中發出「叭」的聲音，是鍋底外側的水滴受熱膨脹後產生的破裂聲音。可能使鍋身或傳熱器受到損害。
● 米未淘洗干淨					●	●				
● 內鍋底凹凸不平	●	●			●					
● 內鍋外側及鍋傳感器之間積有異物	●	●	●		●	●				
● 放入油脂炊飯	●	●				●				
● 炊飯完畢後，沒有攪鬆米飯	●		●							
● 保溫 12 小時以上 或保溫之飯量過少						●	●	●		
● 飯勺插于飯中保溫						●				
● 冷飯保溫或冷飯熱飯混合同時保溫						●				
● 沒有蓋緊鍋蓋						●				
● 內鍋沒有洗干淨或上次煮飯時在鍋中留存的異味					●	●				
● 煮飯時未插掣或是電掣被關閉		●				●				

規格

型號	SR-TE10N	SR-TE15N	SR-TE18N
電源		120 V	
耗電量	煮飯	450 W	630 W
	保溫	61 W	67 W
容量	0.18-1.0 L	0.36-1.5 L	0.54-1.8 L
規格 (高×寬×深) (大約)	9 ⁵ / ₈ " × 9 ³ / ₄ " × 9 ³ / ₄ " (245 x 248 x 247 毫米)	9 ³ / ₄ " × 10 ⁷ / ₈ " × 10 ³ / ₄ " (248 x 276 x 274 毫米)	10 ¹ / ₂ " × 10 ⁷ / ₈ " × 10 ³ / ₄ " (267 x 276 x 274 毫米)
重量 (大約)	2.5 公斤 (5 ¹ / ₂ 磅)	2.8 公斤 (6 ¹ / ₄ 磅)	3.1 公斤 (6 ³ / ₄ 磅)

주의사항

사고의 원인이 될 수도 있는 고장을 방지하기 위해서 다음의 사항을 잘 읽고 숙지합니다.
본 밥솥은 밥을 짓는 용도 외의 다른 목적으로 사용하지 않습니다

- * 사용 안내서의 지시에 따라 쌀과 물의 양을 측정한다.
- 밥솥을 깨끗이 한다. 특히 사용후에는 물 받침대(dew collector)를 청소한다.
- 밥솥 상단 가장자리의 물 받침대 속 구멍(hole)이 막히지 않도록 한다.
- 물받이로 흐르는 구멍을 깨끗하게 유지하고 불순물을 제거한다.
- 줄을 꽂기 전에 기기의 전압이 당신 지역의 공급 전압과 동일한지 확인한다.
- 기기 (unit) 를 물 속에 담그지 마시오.

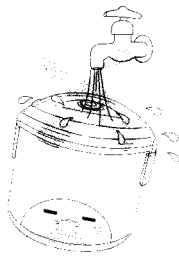

- 밥솥과 가열판 사이에 놓여있는 종이는 사용 전에 제거되어야 한다.
- 줄을 뽑은 후에는 즉시 스위치를 누른다. 모드를 보온 상태로 한 채 밥을 지으면 저열 상태의 조리가 되고 밥이 제대로 될 수 없다.
- 사용 중에는 기기가 뜨거우므로, 뚜껑을 만지거나 밥솥에서 나오는 증기에 얼굴이나 손을 직접 대지 마시오
- 항상 밥솥 바깥쪽 밑면과 가열판을 깨끗하게 건조시켜 보관한다. 두 물체 사이에 이물질이 있을시는 기기 고장의 원인이 된다. 기를 안전한 곳에 두고 물이나 고온 다습한 곳에 방치하지 않는다. 밥솥을 직접 불 위에서 사용하지 않는다.

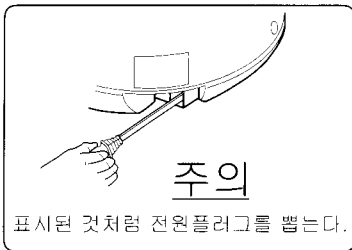

- 어린이의 손이 닿지 않는 곳에 기기를 두며 특히 밤이 되고 있는 동안에는

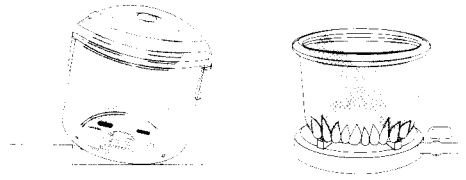

- 주의한다.
- 전원이 연결된 채로 기기를 거꾸로 놓거나 기울어지지 않게 해야 하며, 이는 기기 손상의 원인이 된다. 기기가 기울어졌거나 거꾸로 된 상태일 때는 반드시 전원연결을 해제하여야 한다.
- 최대 눈금치(maximum level)가 넘어가게 밥솥을 채워서는 안된다.
- 뚜껑은 밥이 되는 동안에는 잠금위치(latched position)에서 잘 닫혀있어야 한다.(뚜껑이 열린 채로 기기가 작동되어서는 안된다.)
- 천으로 뚜껑을 덮지 않으며, 이는 변색이나 변형을 일으킬 수 있다.

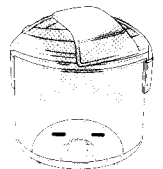

- 전원코드를 손상시키지 말아야 하며 손상 시에는 수리하려고 하지 않는다. 전원코드의 손상을 피하고 절대 코드를 임의로 만드려고 하지 않는다. 코드를 고온한 곳에 두지 않는다. 코드를 불필요하게 구부리거나 비틀지 말고 줄위를 잡아당기지 않는다. 코드 위에는 무거운 물건을 놓거나 묶지 않는다. 손상된 전원코드의 사용은 감전 사고나 누전 혹은 화재의 원인이 될 수 있다.

- 전원코드나 플러그를 수리하려면 주변의 가까운 판매 상담원과 상의한다.

- 플러그가 전원코드에 잘 맞는지 확인 하시오. 전원코드에 플러그를 헐겁게 끼우면 전기안전사고의 원인이 된다.

- 반드시 부착된 코드만을 사용한다.

각 부품의 이름

스팀 캡

- 사용 후에는 떼어서 깨끗이 한다.
22 페이지에 있는 청소와 보관하기를 참조한다.

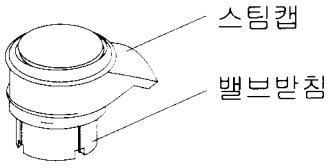

물통

- 옆면을 쥐고 화살표 방향으로 떼어낸다
매번 사용후에는 물통의 물을 제거하고
- 깨끗이 한다

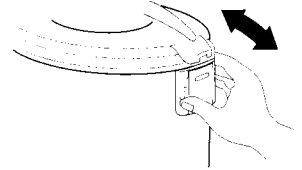

주걱 받침대

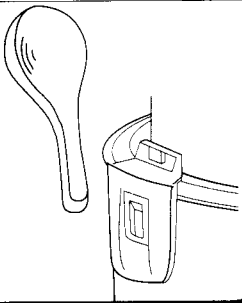

- 조리 중 표시등
- 보온 캠프
- 스위치
- 전원 코드

액세서리(부속품)

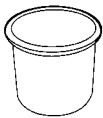

계량컵(대략 180ml)



주걱

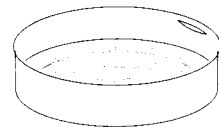

짚기

조리법

1

들어있는 계량컵을 가지고 적당한 쌀의 양을 측정한다
 밥솥이 아닌 다른 그릇에 쌀을 넣고 적당히
 깨끗한 물이 나올 때까지 씻는다.

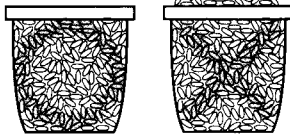

■ 코팅부분이 손상될 수 있으므로
 밥솥에서 쌀을 씻지 않는다.

2

밥 솥에다 씻은 쌀을 넣고 물을 붓는다.
 6 컵 분량의 쌀일 경우, 표시 눈금 6 까지 물을 붓는다.

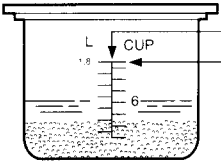

눈금 표시
 최대 눈금
 (이 표시 눈금보다 더 많은 물을 넣고
 밥을 짓지 않는다.)

■ 개인적 취향에 따라 물의 양을
 조절한다.
 ■ 최소한 30분 이상 쌀을 물에
 담가 놓는다.

3

증기캡을 외부 뚜껑에 끼운다.
 밥솥을 본체에 넣는다.
 밥솥을 가열판에 직접 닿도록
 하기위해서 오른쪽에서
 왼쪽으로 조금씩 돌려가며
 바르게 자리잡도록 한다.

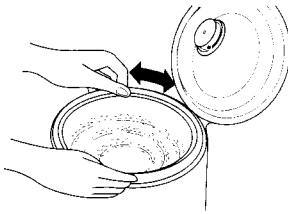

■ 위쪽 뚜껑에 스팀캡을 끼운다 밥솥의
 표면이 젖어 있으면 사용전에 물기를
 잘 제거한다. 젖은 채로 사용하면
 소음의 원인이 되며 이물질은
 고장의 원 인이 됩니다.

4

위 뚜껑을 덮는다.
 뚜껑은 찰칵 소리가 나게 잘 닫는다.

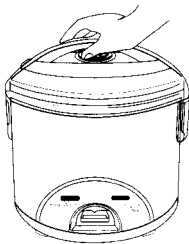

■ 만약 위 뚜껑이 안전하게 잘 닫히지
 않으면 밥이 제대로 지어지지 않는다.
 ■ 사용 중에는 위 뚜껑을 열지 않는다.

5

AC 코드를 밥솥에 꽂고 플러그를 연결한다.
 즉시 스위치를 누른다. 조리가 시작되면 Rice Cook Steam
 램프가 표시해 준다.

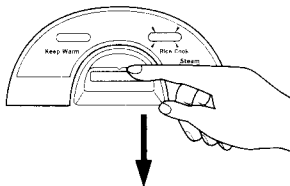
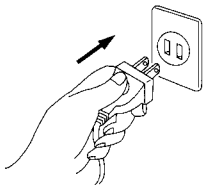

■ 조리중에 전원을 뽑으면 조리가
 완료되지 않습니다.
 ■ 솔이 기계에 장착되지 않으면 전기
 밥솥이 작동하지 않습니다.

6

밥이 다 지어지면, 스위치는 Keep Warm(보온) 상태로 바뀐다.
 Keep Warm 램프가 켜지면 보온기능이 작동하고 있다는 것을 가리킨다.

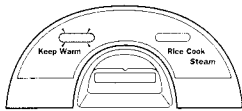

■ 보온 기능은 밥솥의 전원을 뺐
 때까지 계속 유지된다.

7

스위치가 바뀌면, 증기가 쌀을 완전히 뜸 들일 때 까지 최소한
 15분은 뚜껑을 덮은 채로 둔다.

조리법

8

20~30분간 뚝을 들인 후 밥을 퍼서 잘 섞는다.

주걱 보관대

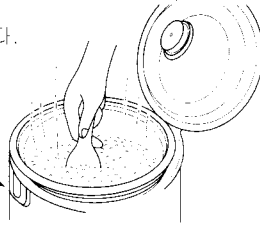

9

기기를 사용하지 않거나 보온하지 않으려면 플러그를 빼놓는다.



10

매번 사용하고 나서는 물받이를 빼서 물기를 깨끗이 없앤다.

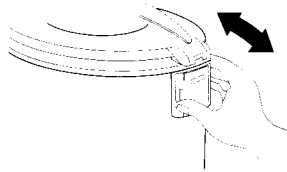

한국어

조리된 밥을 맛있고 따뜻하게 유지하기

- 12 시간 이상 보온기능을 사용하면 밥에서 냄새가 나거나 변색이 될 수 있다.
- 보온 상태로 둘 밥의 양이 다음보다 적지 않도록 한다.

SR-TE18N	6 공기 (6 컵)
SR-TE15N	4 공기 (4 컵)
SR-TE10N	2 공기 (2 컵)

- 보온 상태동안 밥 솥 안에 주걱이나 기타 물건을 넣은 채로 두면 밥의 냄새나 맛이 변할 수가 있다.

찜 용기를 사용해서 하는 찜 요리법

1

들어있는 계량컵을 가지고 물 두 컵을 붓는다.

(밥도 동시에 같이 한다면 다음의 양보다 더 넣지 않는다.)

	쌀 (컵)
1.8L (10 컵)	5
1.5L (8 컵)	4
1.0L (5 컵)	2

2

밥 솥위에 찜기를 놓는다.

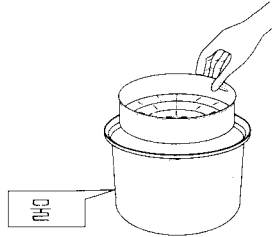

3

밥솥을 본체속에 넣는다.
음식을 담는다. (필요하다면 접시에 담아서 놓아도 된다.)

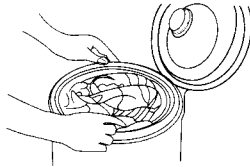

- 밥솥 표면을 사용전에 닦는다. 표면이 젖어있으면 조리 과정에서 소음의 원인이 될 수 있다. 이물질이 표면에 묻어 붙어 있으면 기기손상의 원인이 된다.

4

위 뚜껑위에 스팀램프를 씌우고 뚜껑을 덮는다.
뚜껑을 잠각 소리가 나도록 잘 닫는다.
AC코드를 기기에 잘 부착하고 플러그를 잘 꼽는다.
스위치를 즉시 끈다.
증기가 나오기 시작하면 Rice cook steam 램프가 켜진다.

- 뚜껑이 잘 닫히지 않으면 밥이 제대로 지어지지 않는다
- 조리가 완료되기 전까지는 전원을 뽑지 않는다.
- 전기 밥솥에 솔이 들어 있지 않으면 작동하지 않는다.

5

손으로 조리시간을 맞춘다? (Time the cooking manually)
"기기는 물이 끓어 적절한 온도까지 올라야 자동으로 보온 스위치로 바뀐다"

6

줄을 뽑아 밥솥을 끈다.

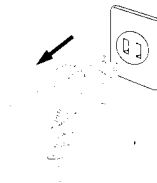

- 기기의 전원을 뽑기 전에는 보온기능이 계속된다.

7

음식을 빼낸 다음, 찜통을 빼내고, 남아있는 물을 부어 버린다.

청소법

- 플러그를 확실히 뽑고 기기가 완전히 열이 식은 후 다음의
- 작업들을 실행한다. 벤젠(benzine)이나 희석제 가루세제 혹은 쇠 수세미 같은 물건을 사용하지 않는다.

본체/ 뚜껑/ 상부 테두리
 젖은 헝겊으로 닦아준다

- 식기세척기 세제를 사용하지 않는다.

밥솥
 식기세척용 세제와 스폰지로 닦아낸다.

물받이
 매번 사용 후에는 제거하고 젖은 천으로 닦는다.

밥솥 센서
 센서에 이물질이 딱딱하게 붙어 있으면, 고온 샌드페이퍼(거칠기 600번정도)/철수세미를 이용하여 문질러 제거한다.
 청소 후 젖은 헝겊으로 잘 닦아준다

부속품

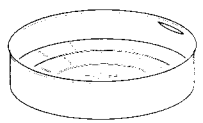

찌기
식기전용세제와 스폰지로 닦는다.

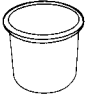

계량컵



주걱

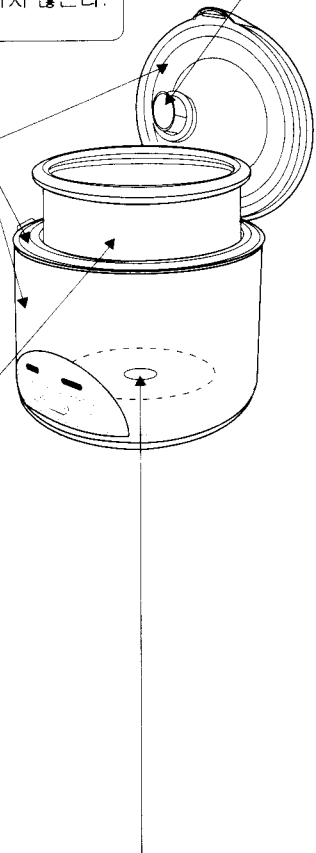

스팀 캡

■ 청소와 보관법

1. 스팀캡을 그림에서같이 떼어내서 벗긴다.



2. 2.밸브 받침대를 오른쪽에서 왼쪽으로 떼어낸다.
 씻고 젖은 헝겊으로 닦아준다.



Bubber

고무를 떼지 말 것.

3. 젖은 헝겊으로 안쪽을 닦아준다.

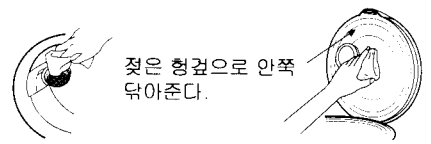

스팀캡 뚜껑을(dome)을 움직이지 마세요.
 전기밥솥 사용법.

● 스팀 캡 끼우는 법

1. 홀더 탭(A)을 캡슬롯(B)에 맞추어 밸브홀더를 스팀캡에 넣고, 왼쪽에서 오른쪽으로 제대로 맞을 때까지 돌린다.

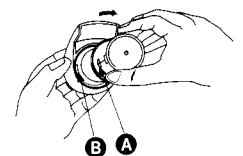

*스팀 돔 사용법

(잘못 건드렸을 경우)

슬롯(D)안에 스팀돔 탭(C)을 넣어 홀더안에 스팀돔을 넣는다. 돔(1)과 스팀캡(2)의 눈금을 정렬시켜 같은 선상에 오도록 한다. 그 다음 스팀돔을 스팀캡에 잘 맞을 때까지 돌려 넣는다("딸깍" 소리가 들린다).



주의: 스팀돔은 한 방향으로만 맞으므로, 힘을 가하면 손상될 수 있다.

2. 위 뚜껑속 구멍(hole)에 스팀 캡을 집어 넣는다.

문제해결

원인	조리시 문제					보온시 문제			전원이 켜지지 않는다	이상한 소리가 난다
	밥이 너무 뜨겁다	밥이 얼었다	밥이 찰다	거품이 끓어 넘친다	바닥이 눌었다	밥에서 이상한 냄새가 난다	밥 색깔이 변한다	밥이 너무 건조하다		
쌀과 물의 비율이 적절치 않음	●	●	●	●	●				보면 스펙에서 볼건 그를 본다. 전원차단기를 점검한다. 전원차단기에 이상이 없으면 가까운 지정 서비스센터에 가져간다.	"펑펑"하는 소리는 스킨과 히터사이 에 갇힌 물이 끓는 소리이며, 스킨과 히터에 손상을 줄 수 있다.
쌀을 제대로 안 씻음					●	●				
스키 기울거나 뒤편 패였음	●	●			●					
스키와 히터 사이에 이물질 있음	●	●	●		●	●				
밥에 기름이 섞였음	●	●				●				
조리 후 밥을 섞지 않았음	●		●							
12시간 이상 보온을 했거나 보온한 밥의 양이 너무 적음						●	●	●		
보온사 이물질이 스킨에 남아 있음						●				
실내온도 또는 더 낮은 온도로 보온이 되었거나 더운 밥에 찬밥을 추가하였음						●				
뚜껑이 제대로 닫히지 않았음						●				
스키 청결하지 않거나 이전의 요리찌꺼기가 남아있음					●	●				
조리시 스위치가 꺼졌거나 전원코드가 연결되지 않았음		●				●				

사양

모델명	SR-TE10N	SR-TE15N	SR-TE18N
전원		120 V	
사용 전압	450 W	630 W	630 W
용량	61 W	67 W	67 W
크기 (H x W x D)	0.18-1.0 L	0.36-1.5 L	0.54-1.8 L
무게	9 5/8" x 9 3/4" x 9 3/4" (245 x 248 x 247 mm)	9 3/4" x 10 7/8" x 10 3/4" (248 x 276 x 274 mm)	10 1/2" x 10 7/8" x 10 3/4" (267 x 276 x 274 mm)
	2.5 kg (5 1/2 lbs.)	2.8 kg (6 1/4 lbs.)	3.1 kg (6 3/4 lbs.)

Attention

Faites bien l'attention en observant les instructions suivants pour prévenir des mauvaises fonctions qui peuvent provoquer d'un accident.

- Ne faites cuire que du riz pas autre choses.
- Suivez les instructions d'opération qui compte surtout la quantité de riz et de l'eau.
- Nettoyer-le bien après chaque usage, surtout le collection de roses.
- Maintenez les orifices d'écoulement vers le collecteur de condensation propres et dégagés de tout résidu.
- Brancher à une prise secteur murale correctement câblée. Avant de brancher, vérifier que la tension de l'appareil est identique à la tension du secteur.

- Ne pas immerger.

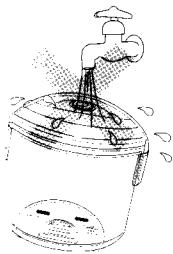

- Avant d'utiliser le cuiseur, retirez le papier placé entre le panier et la plaque chauffante.
- Faites marcher tout de suite le commutateur de chauffage après d'avoir bouché la douille a la propre condition: mais pas celui de rechauffage
- L'appareil chauffe pendant l'utilisation. **NE TOUCHEZ JAMAIS** le couvercle avec la main et ne placez jamais votre visage ou votre main directement au-dessus de la vapeur qui s'échappe du cuiseur.
- Toujours maintenir la plaque chauffante et le fond extérieur du panier parfaitement propres et secs. La présence de matières étrangères entre les deux provoquerait un mauvais fonctionnement du cuiseur.

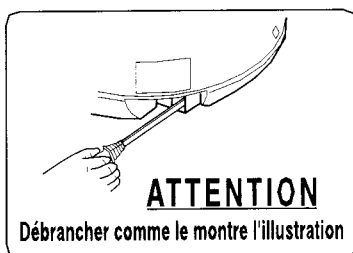

- Mettre le cuiseur sur une surface stable. Ne pas l'exposer a l'eau, a une humidite ou a des sources de chaleur excessives. Ne jamais metre le panier sur une flamme nue.

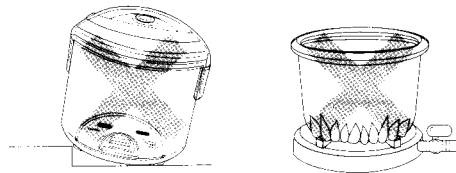

- Faire attention de toujours placer le cuiseur hors de la portee des enfants, plus particulièrement pendant la cuisson du riz.
- Ne pas renverser le cuiseur sur le cote ou le poser a l'envers alors que la prise est branchee car il pourrait etre endommage. S'il doit etre renverse ou mis a l'envers, ne pas oublier de le debrancher auparavant.
- Ne remplissez pas le chaud au dessus du niveau maximum marque.
- Pendant la cuire, la haute couvercle doit etre bien fermee a la position propre. (Il ne fonctionne pas avec la couvercle ouverte).
- Ne pas recouvrir le couvercle avec un chiffon. Le couvercle pourrait se deformer ou changer de couleur.



- Evitez de faire courber, se tordre ou tirer la cordelette de pouvoir sans propre raison ou laisser le placer sous des lourds objects. Quand on trouve le cordelette d'electricite est abimée, ne le réparez pas par soi-meme. Si non, il peuve causer de la secousse életrique ou l'incendie.
 - Consultez au marchand autorisé tout près de chez vous au cas de le faire réparer.
- Assurez-vous que la fiche s'insère à fond dans la prise de courant. Des cordons électriques partiellement enfoncés peuvent entraîner des risques d'électrocution.
 - N'utilisez que les cordelettes données.

Nomenclature

Capuchon d'humidité

- Enlevez - la pour nettoyer tout auprès de chacun usage.
(voir Le Nettoyement et La Maintenance)

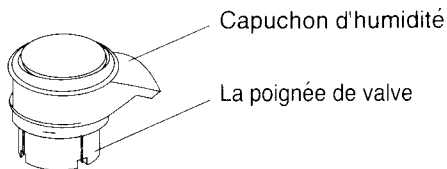

Collecteur de condensation

- Tenir le collecteur par les côtés et suivre la direction des flèches pour l'installer ou le retirer.
- Halten Sie den Kollektor beim Herausnehmen seitlich fest. Zum Einsetzen verfahren Sie in Pfeilrichtung.

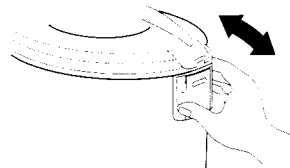

Support de la cuiller

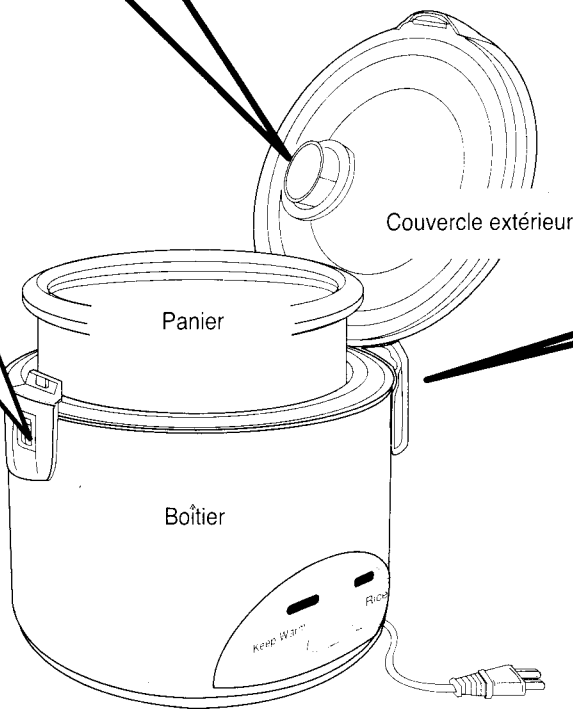
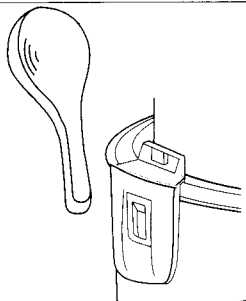

Accessoires

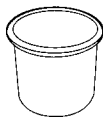

Verre mesureur
(environ 180 ml)



Cuiller à riz

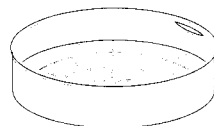

La Corbeille a vaporisation

FRANÇAIS

Mode d'emploi

1

Mesurer le riz à l'aide du verre mesureur fourni. Laver le riz dans un autre bol jusqu'à ce que l'eau qui s'écoule soit limpide.

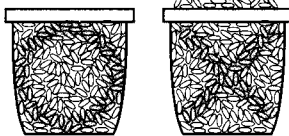

- Ne rincez jamais le riz dans le panier du cuiseur. Vous risqueriez d'endommager le revêtement anti-adhésif.

2

Mettre le riz lavé dans le panier. Ajouter l'eau.
Ex.: Pour six tasses de riz, mettre de l'eau jusqu'au niveau 6

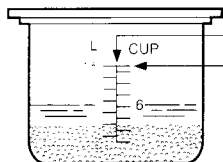

Indicateur de niveau

Niveau maximum

Ne pas remplir au-delà de ce niveau.
(Ex.: modèle de 1,8 L)

- Ajouter la quantité d'eau selon les préférences.
- Faites baigner, avant la cuire, du riz au moins 30 minutes.

3

Fixer le couvercle intérieur au couvercle extérieur. Placer le panier dans le boîtier. S'assurer que le panier est directement en contact avec la plaque chauffante, en le tournant légèrement vers la droite puis vers la gauche pour qu'il s'installe proprement.

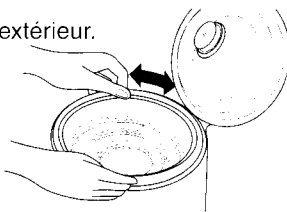

- Tenez bien sec entièrement au surface de la casserole avant de la placer sur place pour faire marcher l'électricité. Si non, le rechaud fera la bruit pendant la cuire ou il doit être en dommage.

4

Fermer le couvercle extérieur. S'assurer que le couvercle est bien enclenché et verrouillé.

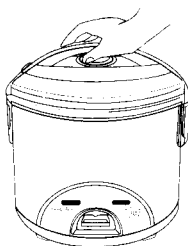

- Si le couvercle n'est pas bien fermé, la cuisson en sera affectée.
- Ne pas ouvrir le couvercle extérieur pendant la cuisson.

5

Brancher le cordon dans la prise de l'appareil. Abaisser le commutateur. Le témoin du cuiseur (Rice Cook) s'allume pour indiquer le début de la cuisson.

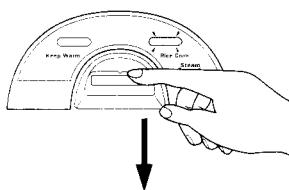
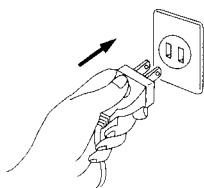

- Ne pas brancher avant que tout soit prêt à la cuisson, autrement, le riz pourrait être gâté.
- Si le panier n'est pas inséré dans l'appareil, la cuisson ne peut débuter.

6

La cuisson terminée, le commutateur se déplace à la position de maintien au chaud. Le témoin de maintien au chaud (Keep Warm) s'allume pour indiquer la mise en service de la fonction de maintien au chaud.

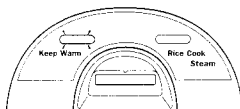

- La fonction de maintien au chaud demeure en fonction jusqu'à ce que l'appareil soit débranché.

7

Après que le commutateur ait changé de position, laisser le cuiseur sous couvert pendant environ 15 minutes pour que la cuisson à la vapeur du riz se poursuive.

Mode d'emploi

8

Mélangez bien le riz à l'aide d'une cuillère 20 à 30 minutes après la cuisson.

support de la cuiller

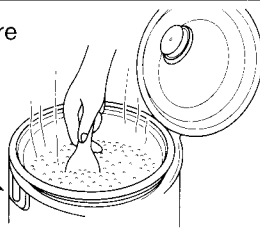

9

Débranchez l'appareil lorsque vous ne l'utilisez pas ou lorsque vous ne souhaitez pas maintenir le riz au chaud.

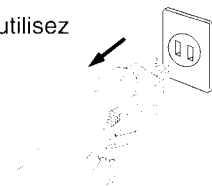

10

Après chaque usage, retirer et nettoyer le collecteur de condensation.

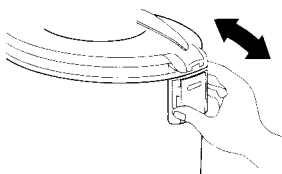

FRANÇAIS

Pour maintenir le riz cuit au chaud et lui conserver toute sa saveur

- Ne pas maintenir le riz au chaud plus de 12 heures; autrement, il pourrait devenir décoloré et dégager une odeur.
- Si la quantité de riz à maintenir au chaud est inférieure à,

SR-TE18N	6 portios (6 tasses)
SR-TE15N	4 portios (4 tasses)
SR-TE10N	2 portios (2 tasses)

le riz deviendra sec et sans saveur.

- Ne laisser aucun ustensile dans le panier pendant le maintien au chaud; cela pourrait altérer l'odeur et le goût du riz.

Cuisson à la vapeur (Avec grille à vapeur en option)

1

Mesurer 2 verres d'eau avec le verre mesureur fourni.
Verser l'eau dans le panier.

Si vous faites cuire en même temps du riz, vous ne pouvez jamais remplir un rechaud tant et plus de la capacité unique de chaque modèle.

Modele	(Tasse) du riz
1,8L (10 tasses)	5
1,5L (8 tasses)	4
1,0L (5 tasses)	2

2

Deposer la grille a vapeur dans le panier.

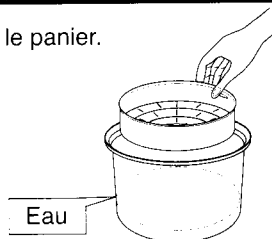

3

Après avoir placé des plats pleins de nourriture dans cette corbeille, réglez-la bien en propre position de la casserole.

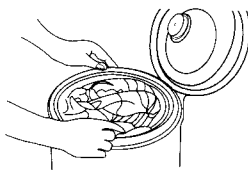

- Avant usage, essuyer la surface du panier. S'il est humide, cela pourrait entraîner du bruit pendant la cuisson voire endommager l'appareil.

4

Fermez la haute couvercle en claquant pour permettre à fonctionner la toque de vapeur là-dessous.
Attachez la cordelette d'AC sur place pour faire marcher la lampe de cuire qui s'éclaire tout de suite.

- Afin de prévenir des problèmes de cuisson, s'assurer que le couvercle extérieur est bien fermé.
- Ne brancher l'appareil que lorsque la cuisson doit débuter. Sinon, les aliments pourraient être gâtés.
- La cuisson ne pourra commencer en l'absence du panier.

5

Régler manuellement la durée de cuisson.
L'appareil passe en mode maintien au chaud lorsque l'eau est évaporée.

6

Couper le contact sur l'appareil en le débranchant.

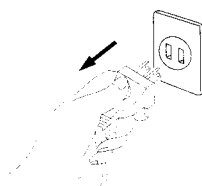

Son système de rechauffage continue à marcher un peu plus tard après le détachement.

7

Retirez les aliments, la corbeille à vaporisation, puis videz l'eau restante.

Nettoyage

Soyez sûrs que vous avez fait de la douille et bien terminer tout le système automatique tant que ce rechaud revient froid.
Le nettoyage avec la benzine, le thinner ou celui de poudre à nettoyer est en tous cas interdit.

Boîtier / Couvercle extérieur / La Haute

Couvercle / Le Bord de carrosserie
Faites sécher-les tout simplement avec une moite éponge sans aucune produit à laver.

La Casserole

Lavez à l'aide d'un nettoyant à vaisselle et d'une éponge, puis essuyez.

Collecteur de condensation

Retirez et nettoyez avec un chiffon humide après chaque utilisation.

La Communitateur de casserole

Si un objet reste collé au capteur, retirez-le en frottant légèrement avec du papier abrasif fin (numéro 600 environ) ou avec de la laine de verre. Et puis finalement réfléchissez-la avec une moite étoffe.

Accessoires

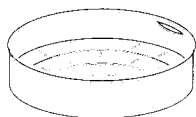

Vaporisation

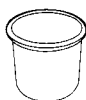

Verre mesureur



Cuiller à riz

Avec une bonne éponge plus du produit à laver.

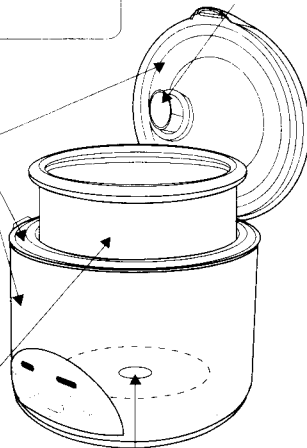

La Toque de vapeur

■ Comment fait-on le détachement

1. Enlevez-la d'une façon présentée dans cette image.

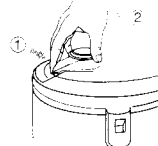

2. Tournez de droite à gauche le poignée de valve. Lavez-la tout simplement avec le courant d'eau tout avant de la faire sèche avec une moite étoffe.



Ne retirez pas le caoutchouc

3. Faites partir aussi l'humidité là-dedans avec une fine étoffe.



faire sèche avec une moite étoffe.

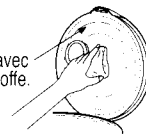

Veuillez ne enlever pas le vapeur-couvercle quand vous utilisez la marmite de riz.

■ Comment fait-on la remettre en place.

1. Insérez la poignée de la valve dans le capuchon d'humidité en plaçant le taquet de la poignée (A) dans la fente du capuchon (B), puis tournez de gauche à droite jusqu'à ce que la poignée soit bien en place.

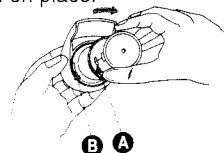

■ Comment emboîter le vapeur-couvercle.

(En cas il est enlevé par hasard.)

Placez le couvercle à vapeur dans son support en insérant les taquets (C) dans la fente (D). Alignez les repères du couvercle (1) et du capuchon d'humidité (2). Enfoncez ensuite le couvercle à vapeur dans le capuchon d'humidité jusqu'à ce qu'il s'insère correctement (à ce stade, vous entendrez un dé clic).

Remarque :

Le couvercle à vapeur ne peut s'insérer que dans un sens.

Ne forcez jamais pour l'insérer, vous risqueriez de l'endommager.

2. Montez la toque de vapeur à la rainure de celle de haute couvercle.

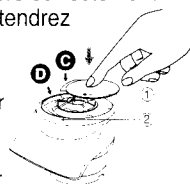

Guide de dépannage

Description du problème	Problèmes de cuisson					Problèmes de maintien au chaud			Pas de courant	Emission de sons étranges
	Le riz est trop dur.	Le cœur du riz n'est pas cuit.	Le riz est trop mou.	Un liquide visqueux déborde.	Le fond est légèrement brûlé.	Le riz a une odeur inhabituelle.	Le riz change de couleur.	Le riz est trop sec.		
Causes possibles										
La quantité riz-eau n'est pas correcte	●	●	●	●	●					
Le riz n'est pas suffisamment rincé					●	●				
Le fond du panier est cabossé ou inéga	●	●			●					
Des corps étrangers se sont glissés entre le panier et la partie chauffante.	●	●	●		●	●	●			
Le riz est cuit avec de l'huile.	●	●				●				
Le riz n'a pas été remué (mélangé) après la cuisson	●		●							
Le riz a été maintenu au chaud pendant plus de 12 heures ou la quantité de riz à maintenir au chaud est insuffisante.						●	●	●		
Les ustensiles sont restés dans le panier pendant le maintien au chaud.						●				
Le riz à maintenir au chaud était à température ambiante ou température plus froide ou du riz froid a été ajouté au riz chaud.						●				
Le couvercle n'est pas fermé correctement.						●				
Le panier n'était pas propre ou contenait encore des odeurs de cuissons précédentes.					●	●				
Le cordon d'alimentation a été débranché ou l'interrupteur a été mis hors tension pendant la cuisson.		●				●				

Débranchez l'appareil de la prise secteur. Vérifiez le disjoncteur. Si le disjoncteur n'a pas sauté, apportez l'appareil au service technique agréé le plus proche.

L'eau emprisonnée entre le panier et la partie chauffante peut lors de son évaporation produire des bruits bizarres et endommager le panier ainsi que la partie chauffante.

Spécifications

Modèle No.	SR-TE10N	SR-TE15N	SR-TE18N
Alimenttion		120 V	
Consommation	Cuisson	450 W	630 W
	Maintien au chaud	61 W	67 W
Capacité	0,18-1,0 L	0,36-1,5 L	0,54-1,8 L
Dimensions (H x L x P) (approx.)	9 ⁵ / ₈ po x 9 ³ / ₄ po x 9 ³ / ₄ po (245 x 248 x 247 mm)	9 ³ / ₄ po x 10 ⁷ / ₈ po x 10 ³ / ₄ po (248 x 276 x 274 mm)	10 ¹ / ₂ po x 10 ⁷ / ₈ po x 10 ³ / ₄ po (267 x 276 x 274 mm)
Poids (approx.)	2,5 kg (5 ¹ / ₂ lb)	2,8 kg (6 ¹ / ₄ lb)	3,1 kg (6 ³ / ₄ lb)

Matsushita Electric Industrial Co., Ltd.

Web Site : <http://www.panasonic.co.jp/global/>

RZ19A6161
C0204T0
Printed in Thailand.